

ANSWERS		
1	WC in wrong position. No window.	2
2	Line across door entrance is for external doors only.	1
3	No backdoor.	1
4	Sectioning.	1
5	Built in cupboards.	1
6	Cutting plane A-A.	1
7	An arched opening.	2
8	Incomplete window detail.	1
9		4
10		3
11	South Elevation.	1
12	Scale 1 : 50	1
13	220 mm.	1
14	$4,2 \times 4,2 = 17,64 \text{ m}^2$	3
15	$(10 \times 2) + (12 \times 2) = 44 \text{ m}$	3
16	$37 \times 50 = 1,85 \text{ m}$	2
17	North point	1
18		1
		<b>30</b>

ANTWOORDE		
1	WC in verkeerde posisie. Geen venster.	2
2	Lyn oor deuropening slegs vir buitedeure.	1
3	Geen agterdeur.	1
4	Arsering.	1
5	Ingeboudekaste.	1
6	Snyvlak A-A.	1
7	'n Geboë opening.	2
8	Onvoltooide vensterbesonderhede.	1
9		4
10		3
11	Suidaansig.	1
12	Skaal 1 : 50	1
13	220 mm.	1
14	$4,2 \times 4,2 = 17,64 \text{ m}^2$	3
15	44 m	3
16	$37 \times 50 = 1,85 \text{ m}$	2
17	Noordpunt	1
18		1
		<b>30</b>

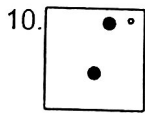
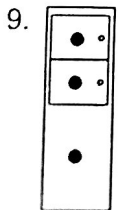

FREEHAND  
VRYHAND

18. FLOOR PLAN  
VLOERPLAN

MEMORANDUM

FREEHAND  
VRYHAND

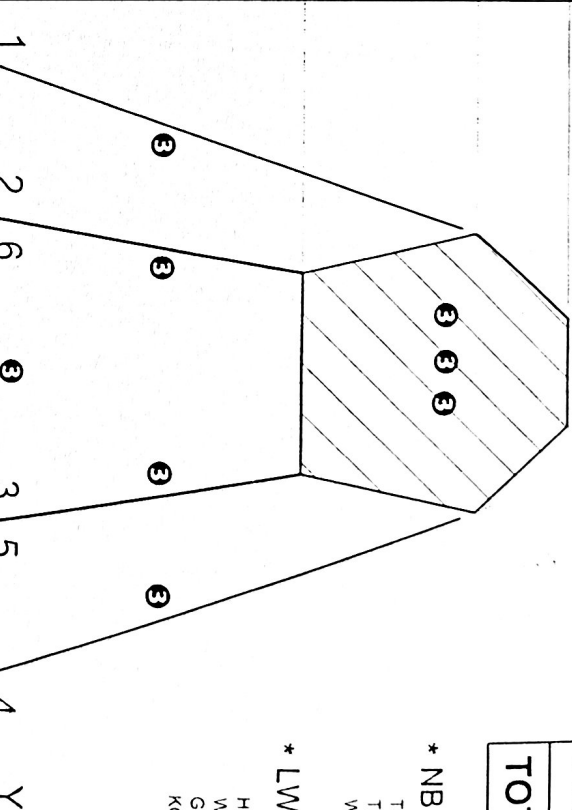
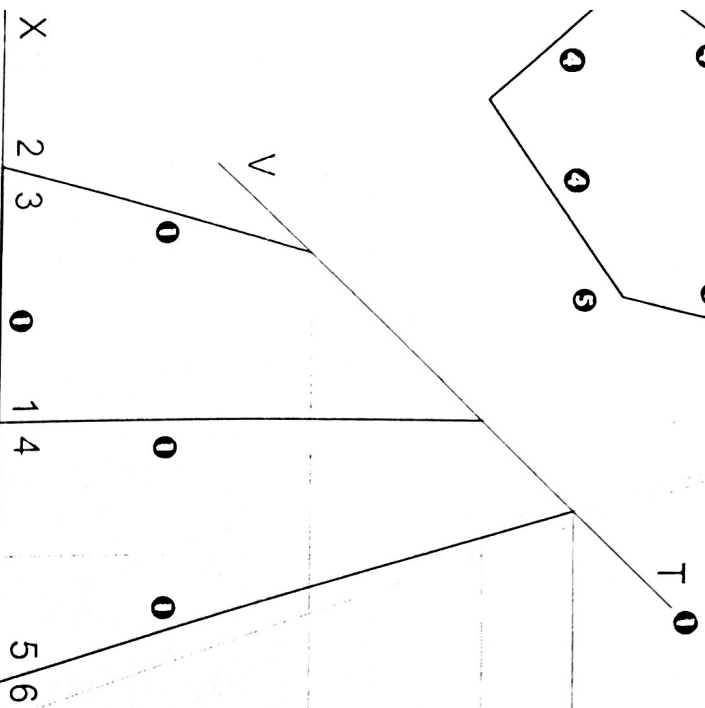
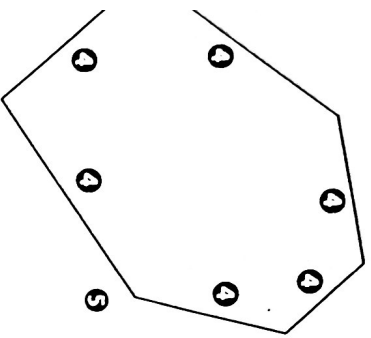

1 Front view	
2 Sectional top view	
3 Sectional left view	
4 True shape	
5 Constructions	
<b>TOTAL</b>	

\* NB  
THESE TWO MARKS MAY BE GIVEN  
IF THE SECTION IS DRAWN CORRECTLY  
WITHOUT THESE CONSTRUCTIONS.

\* LW  
HIERDIE TWEË PUNTE MAG TOEGEK  
WORD INDIEN DIE SNIT KORREK  
GETEKEN IS SONDER HIERDIE  
KONSTRUKSIES.

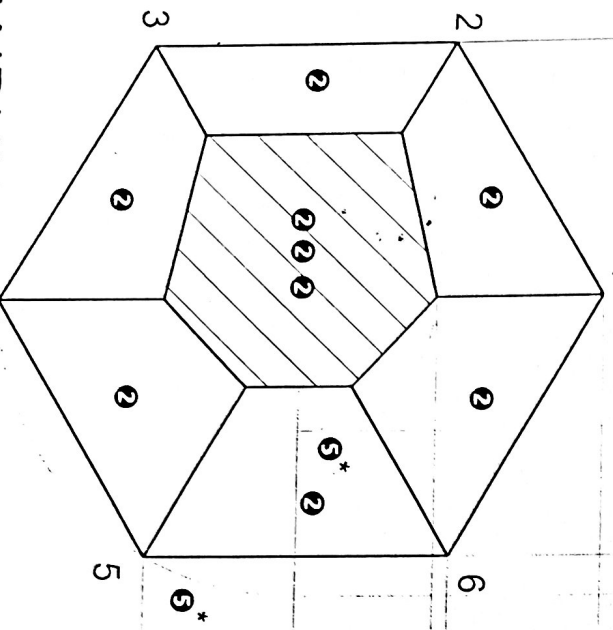

<b>ASSESSERINGSKRITERIA</b>	
1 Vooraansig	6
2 Deursnee-boaansig	6
3 Deursnee-linkeraansig	6
4 Ware vorm	6
5 Konstruksies	6
<b>TOTAL</b>	<b>30</b>

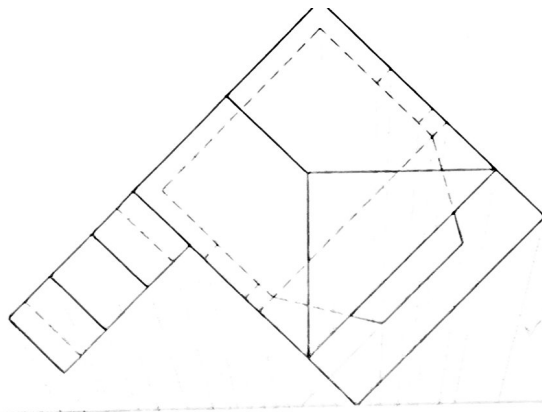

PP

LVP  
HL

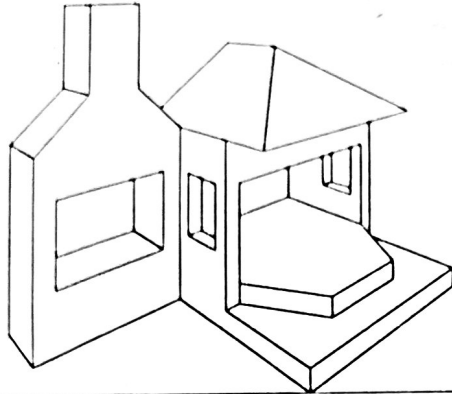

RVP  
HL

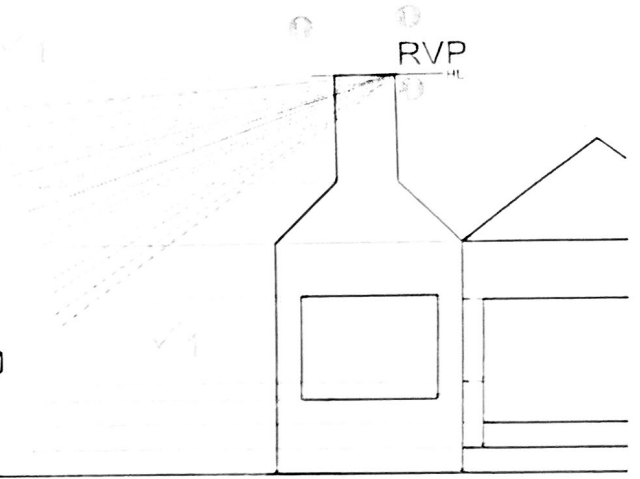

G

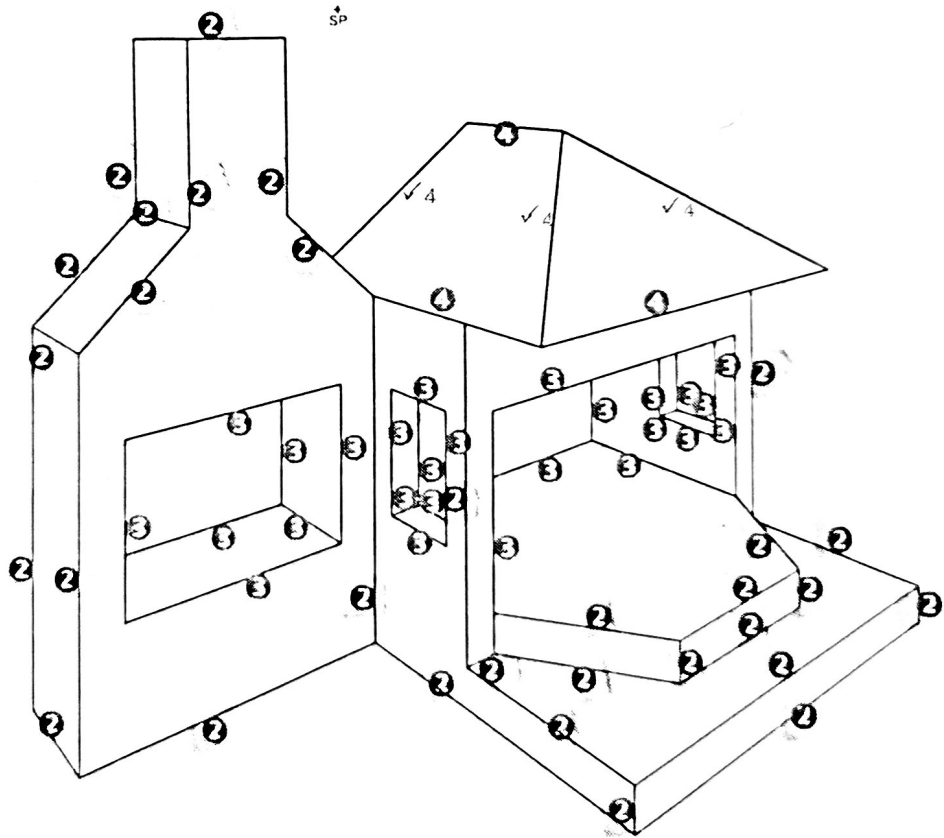

SP

+  
SP

ASSESSMENT CRITERIA			ASSESSERINGSKRITERIA		
1	CONSTRUCTION + VPs	8	1	KONSTRUKSIE + VPs	8
2	WALLS + STEPS	15 $\frac{1}{2}$	2	MURE + TRAPPE	15 $\frac{1}{2}$
3	OPENINGS	13	3	OPENINGE	13
4	ROOF	4 $\frac{1}{2}$	4	DAK	4 $\frac{1}{2}$
TOTAL		41	TOTAAL		41

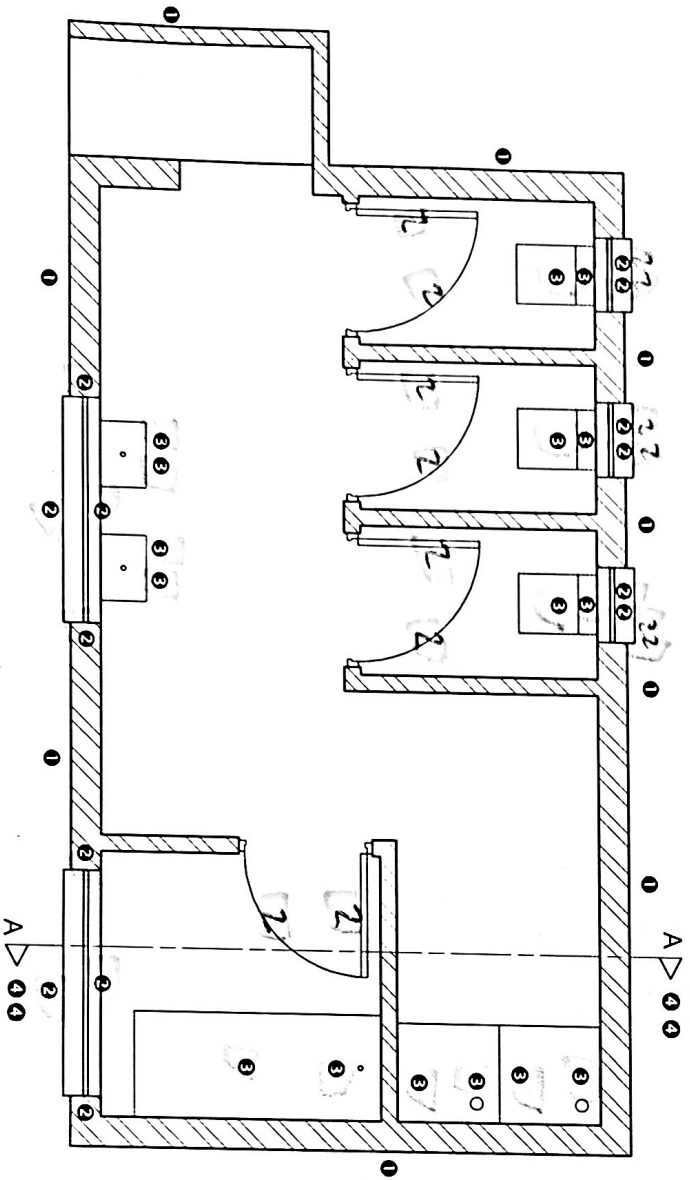
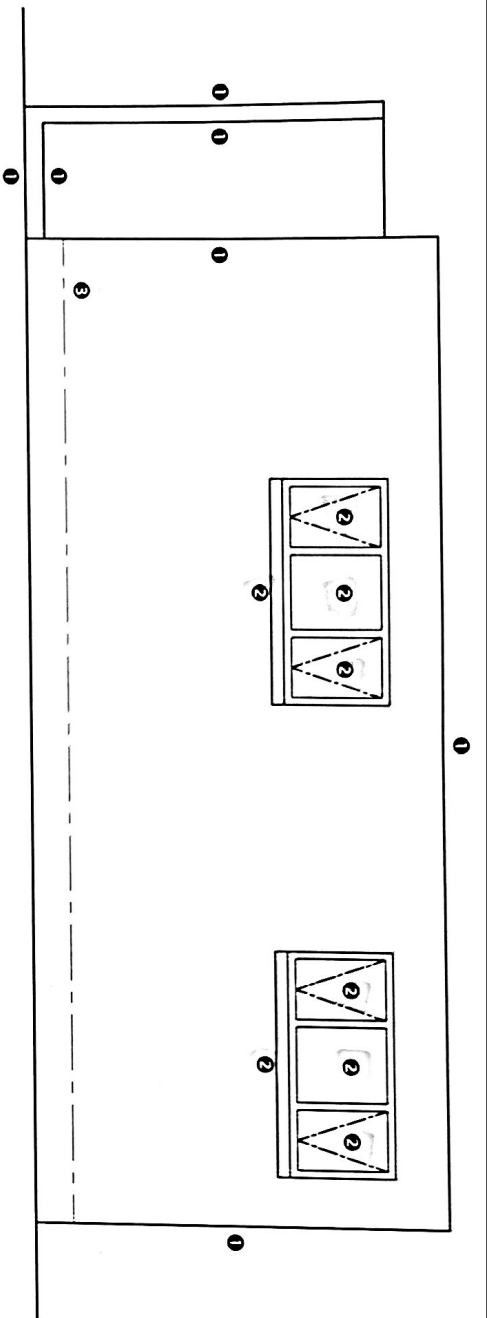

FLOOR PLAN	
WALLS AND WINDOWS	14
DOORS	9

VLOERPLAN	
1 ARSERING	9
2 DEURE EN VENSTERS	14

qrv  
N2872

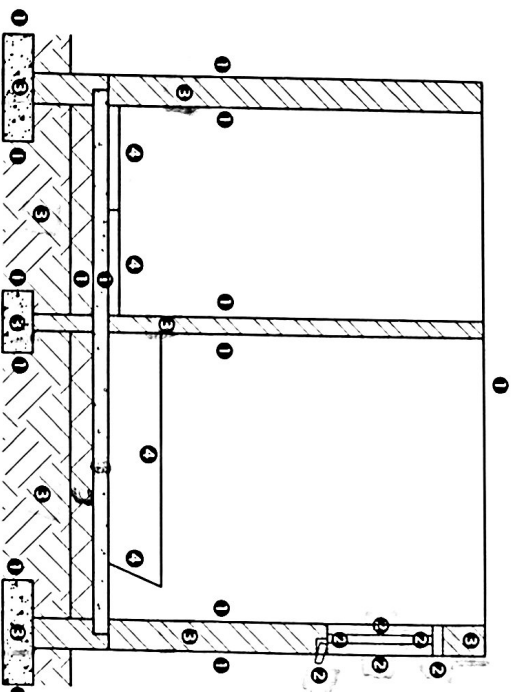

SECTIONAL ELEVATION A-A  
SNITAANSIG A-A

SECTION	
WALLS AND WINDOWS	15
DOORS	6

Vu